

SMDs are available on 8 mm blister tape, to be used on automatic placement systems. In case of standard taping the orientation of the SMDs is shown in the following figures for SOD-80, SOT-23 and SOT-143. The mounting side of the components is oriented to the bottom side of the tape

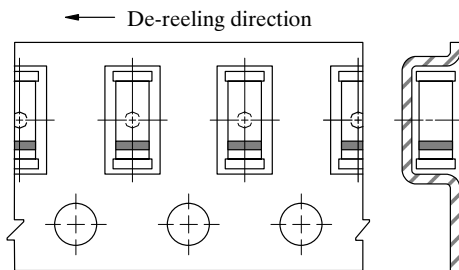

Figure 1. Standard taped SOD-80

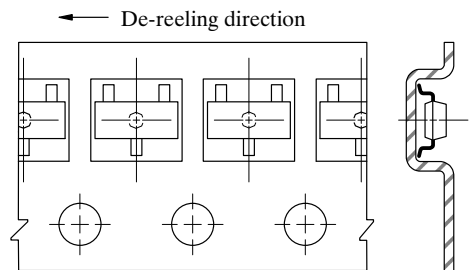

Figure 2. Standard taped SOT-23

Designation is attached with code GS 08/18 in case of standard taping for SMDs

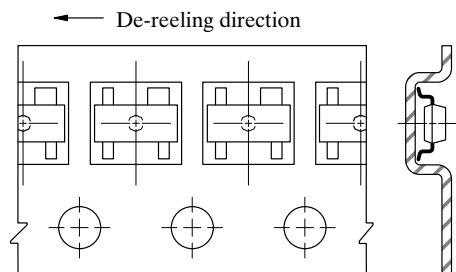

Figure 3. Standard taped SOT-143

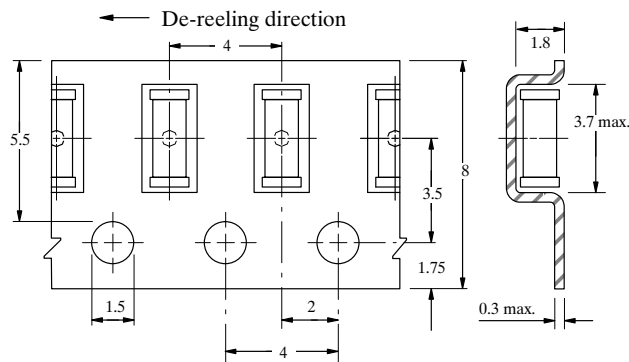

Figure 4. Tape dimensions for SOD-80 in mm

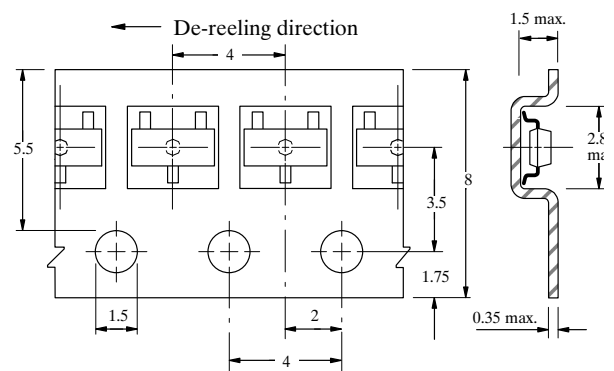

Figure 5. Tape dimensions for SOT-23 and SOT-143 in mm

Quantities per reel: SOD-80: 2,500 components (GS 08)
10,000 components (GS 18)

SOT-23/143: 3,000 components (GS 08)
10,000 components (GS 18)

Missing devices: Maximum of 0.5% of the total number of components per reel may be missing, exclusively missing components at the beginning and at the end of the reel. Maximum of three consecutive components may be missing, provided this gap is followed by six consecutive components. See Figure 6.

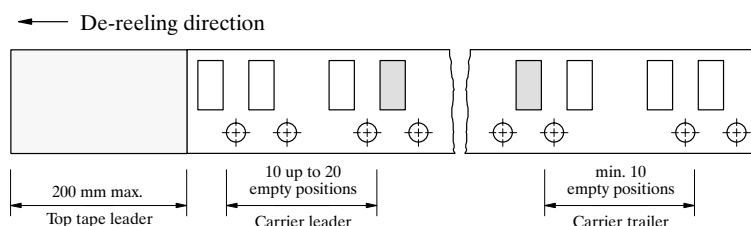

Figure 6. Beginning and end of the reel

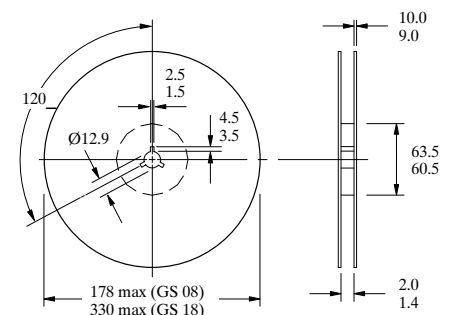

Figure 7. Dimensions of the reel in mm